

MOLYKOTE® Lubricants for wind turbines

Long-lasting, high-performance lubrication ensures superior reliability, greater uptime and reduced cost of ownership

Ensuring superior reliability & greater uptime of turbines

It is projected that the global demand for energy will undergo double-digit growth in the coming years. To help satisfy this demand, reduce emissions and slow the effects of climate change, investment in renewable energy is imperative. Wind energy, especially offshore, will be a critical pillar in the shift toward green power generation. Efficiency of wind turbines has greatly increased over the last decades and still has the potential to improve further. Lubricants will play a crucial role in this evolution. MOLYKOTE® Specialty Lubricants are already increasing reliability, performance and uptime of wind turbines and will continue to do so with new developments in the next generation of wind turbines.

1 Threaded connections

MOLYKOTE® Thread Pastes
(e.g., MOLYKOTE® 1000 Paste or MOLYKOTE® G-Rapid Plus Paste)

Ensure proper tightening and release torque of threaded connections, which contributes to safe, reliable operations while simplifying maintenance, even after long operation times.

2 Pitch bearings

MOLYKOTE® Longterm 2 Plus Extreme Pressure Bearing Grease

Ensures long-lasting operation of pitch bearings by providing sufficient lubrication and preventing false brinelling effectively.

3 Shrink disc

MOLYKOTE® D-321 R Anti-Friction Coating (ring) & MOLYKOTE® 1000 Paste (bolts)

Go-to solutions for lifetime lubrication of the shrink disc.

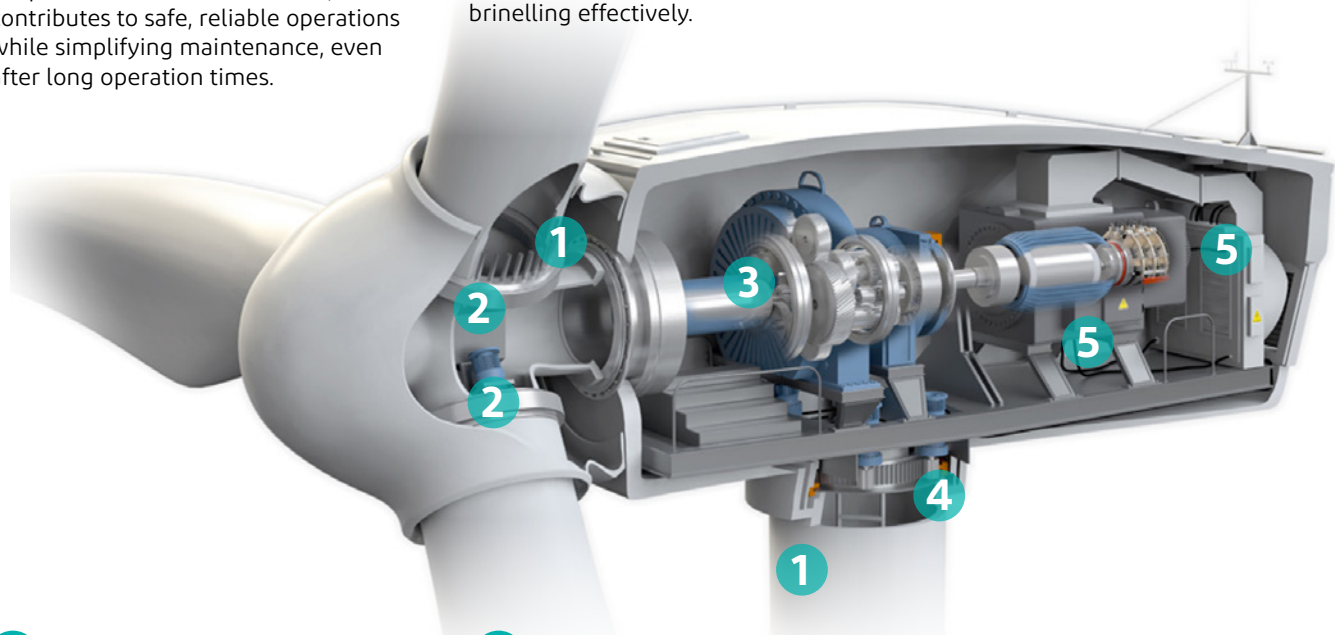

4 Yaw brake

MOLYKOTE® 3402-C LF Anti-Friction Coating

Reduces noise emissions and extends service life of the braking system.

5 High-voltage connectors

MOLYKOTE® 111 Compound

Preferred choice for any high-voltage connector; simplifies assembly and provides extra sealing performance against moisture.

EmPOWER the world with the essential innovations to thrive



Threaded connections (foundation, tower, nacelle, blades)

Thread pastes: **MOLYKOTE® 1000 Paste**, **MOLYKOTE® G-Rapid Plus Paste** or **MOLYKOTE® P-74 Assembly Paste**

- Ensure proper tightening & release torque
- Consistent coefficient of friction
- Prevent seizing
- Enable multiple assembly & disassembly cycles
- Provide additional corrosion protection (*MOLYKOTE® 1000 Paste & MOLYKOTE® P-74 Paste*)

Consistent friction over multiple tightenings

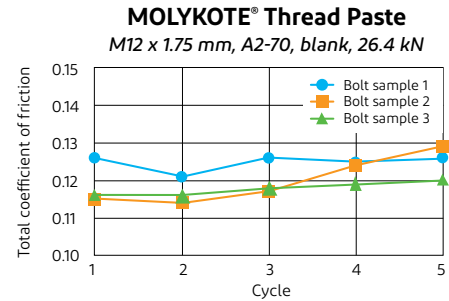

Shrink disc

MOLYKOTE® D-321 R Anti-Friction Coating (ring)

- Lowers friction & wear
- Lifetime lubrication
- Simplifies assembly
- Prevents fretting
- Dry-film lubricant

MOLYKOTE® 1000 Paste (bolts)

- See "Threaded connections" above



Pitch bearings

MOLYKOTE® Longterm 2 Plus Extreme Pressure Bearing Grease

- Long-lasting lubrication
- High load-carrying capacity
- Prevents false brinelling
- Good corrosion protection

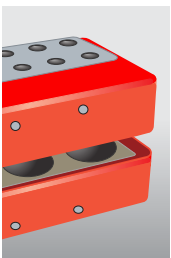

Yaw brake

MOLYKOTE® 3402-C LF Anti-Friction Coating

- Reduces wear between jacks & backside of brake pads
- Reduces noise emissions caused by stick-slip



High-voltage connectors

MOLYKOTE® 111 Compound

- Assembly aid
- Increases sealing performance against moisture
- High-voltage resistance

About MOLYKOTE® Specialty Lubricants

Since 1948, customers around the world have trusted the MOLYKOTE® brand for performance and expertise to help solve complex, technical design and lubrication challenges. To learn more about our extensive product and service offering, to utilize our interactive product selection tool, or to locate a distributor, visit molykote.com.



We have Contact Centers around the globe. Find the phone number for the center nearest you at www.dupont.com/molykotecontact.



DuPont™, the DuPont Oval Logo, and all trademarks and service marks denoted with ™, SM or ® are owned by affiliates of DuPont de Nemours, Inc. unless otherwise noted.
© 2024 DuPont.

The information set forth herein is furnished free of charge and is based on technical data that DuPont believes to be reliable and falls within the normal range of properties. It is intended for use by persons having technical skill, at their own discretion and risk. This data should not be used to establish specification limits nor used alone as the basis of design. Handling precaution information is given with the understanding that those using it will satisfy themselves that their particular conditions of use present no health or safety hazards. Since conditions of product use and disposal are outside our control, we make no warranties, express or implied, and assume no liability in connection with any use of this information. As with any product, evaluation under end use conditions prior to specification is essential. Nothing herein is to be taken as a license to operate or a recommendation to infringe on patents.